

Electric field

SLDIE 1

QUESTION 1

Materials may be charged with either positive or negative charge. Classify the following materials according to whether they receive a positive or negative charge by friction.

- (1) amber
- (2) glass
- (3) ebonite rubbed with fur
- (4) polythene
- (5) silk
- (6) hair
- (7) cellulose acetate
- (8) fur

SLIDE 2

Solution

Negative charge amber, silk, polythene (plastic), hair

Positive charge glass, ebonite*, cellulose acetate, fur

* If ebonite is rubbed with fur, electrons are transferred from the fur to the ebonite, and the ebonite becomes negatively charged. Thus, the transfer of electrons and charge induced by friction depends on the materials used.

SLIDE 3

QUESTION 2

What is the process of **electrostatic induction**? How may two isolated spheres be charged by electrostatic induction?

SLIDE 4

Solution

Charging by induction. An **induced charge** is a charged produced by **electrostatic induction** without contact

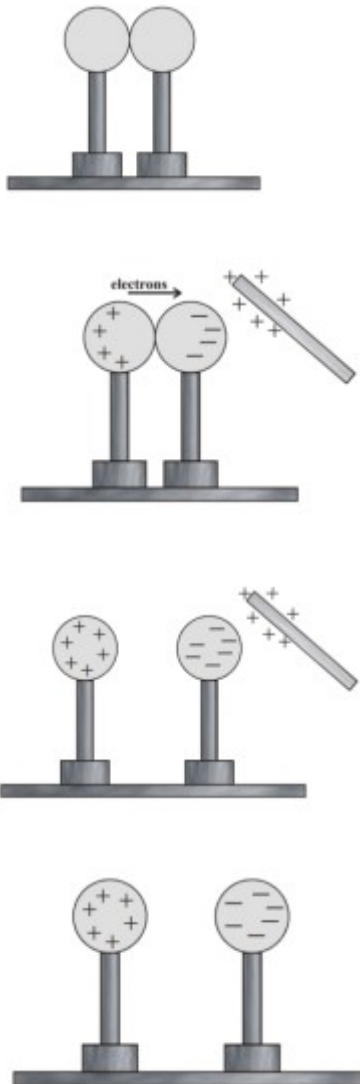

SLIDE 5

QUESTION 3

Make a drawing of a cold-leaf electroscope

SLIDE 6

Gold-leaf electroscope

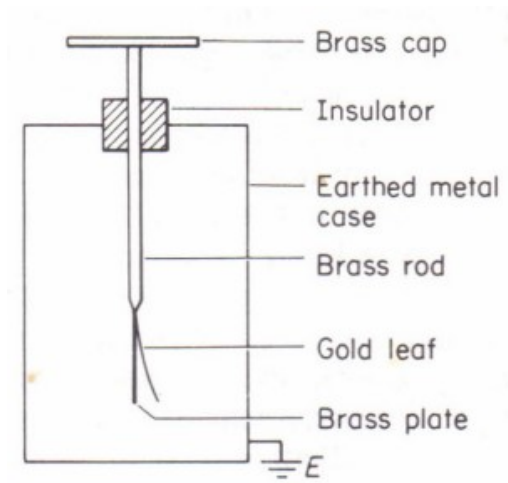

SLIDE 7

QUESTION 4

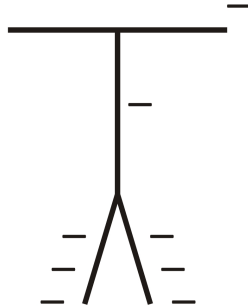

The diagram shows a gold-leaf electroscope that has been negatively charged.

Make a similar diagram showing the effect on the electroscope of bringing a negatively charged rod close to the brass cap of the electroscope, though not touching it.

SLIDE 8

Solution

Before

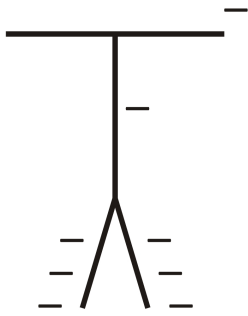

After

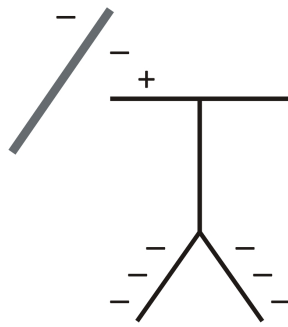

SLIDE 9

QUESTION 5

Join up the field lines between these two pairs of pa



SLIDE 10

00016250015

Solution

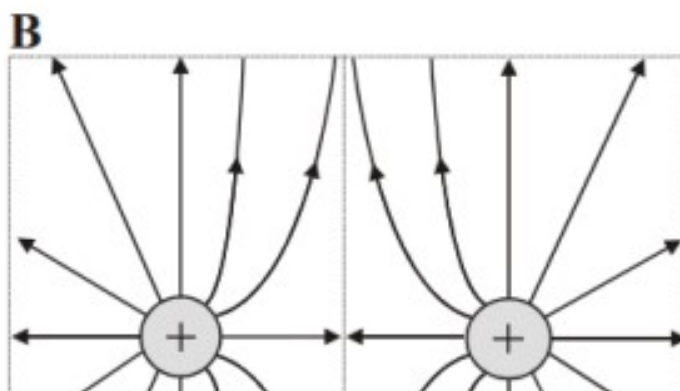
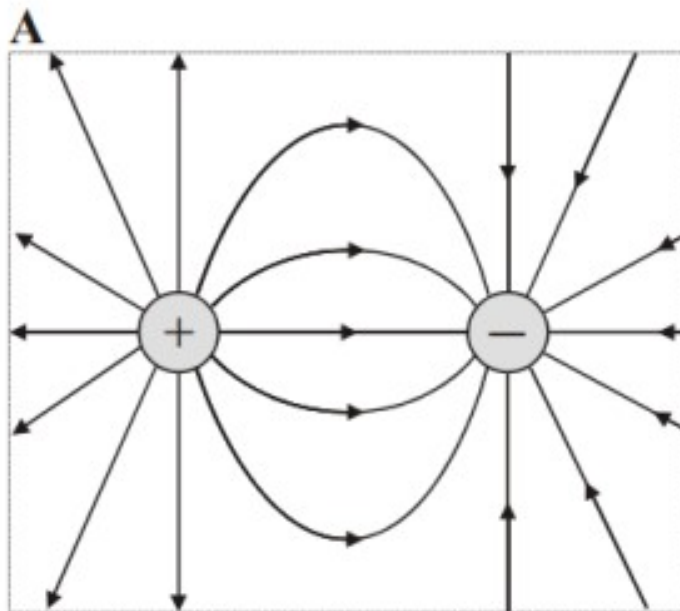

SLIDE 11

QUESTION 6

Make a diagram illustrating Faraday's ice-pail experiment.

Faraday's ice-pail experiment

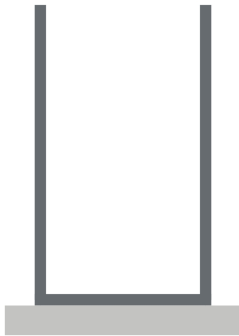

An ice-bucket or pail is resting upon an insulated surface.

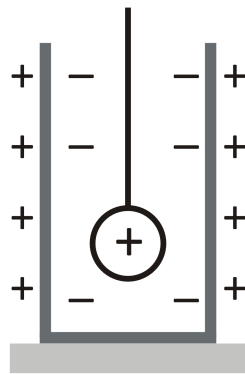

A positively charged metal sphere is lowered into the ice-pail. This induces a negative charge on the inside of the bucket and a positive charge on the outside.

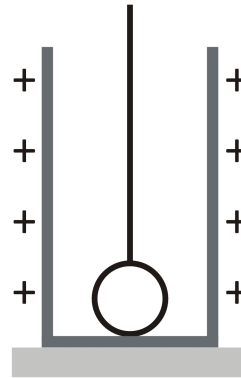

When the metal sphere is further lowered so that it touches the bottom of the bucket, it is discharged. The charge on the metal sphere has been transferred to the outside of the bucket.

SLIDE 13

QUESTION 7

What is Faraday's principle?

SLIDE 14

Faraday's principle is the principle that the total charge inside a hollow conductor is always zero.

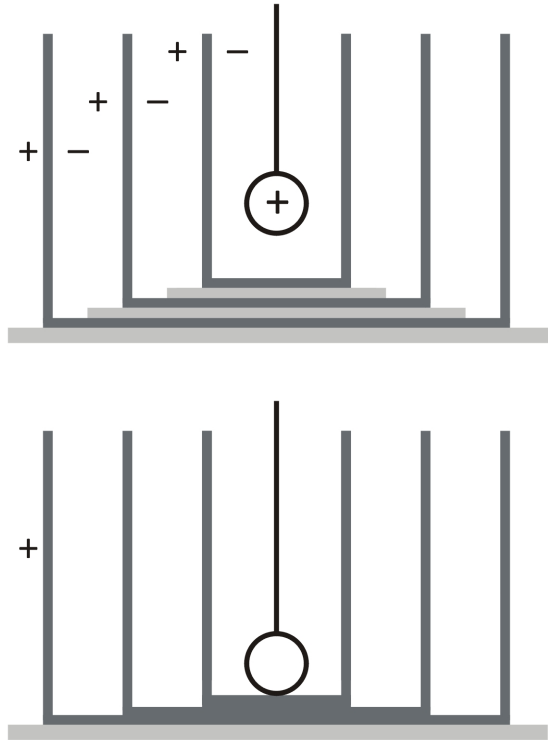

SLIDE 15

QUESTION 8

What is a Faraday cage?

SLIDE 16

Faraday cage



It is impossible to receive an electric shock when wholly **inside** a conductor.

SLIDE 17

QUESTION 9

Make a diagram showing a Van der Graff generator, and explain how a charge may be accumulated on a metal dome by means of one.

SLIDE 18

Van der Graaff generator

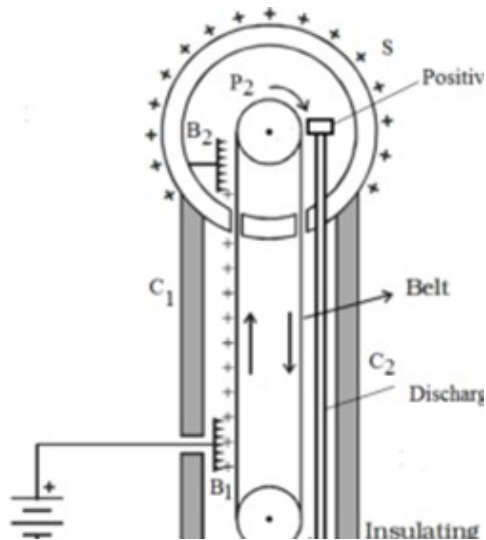

A **Van der Graaff** generator is a device for accumulating charge on the surface of a metal sphere or dome.

- ① B_1 is connected to a positive end of a battery. Electrons are attracted from the belt to the battery at B_1 . This leaves a positive charge on the belt. The motor carries this charge along the belt towards the dome, so the charge cannot accumulate at B_1 .
- ② At B_2 electrons in the dome are attracted to the positive charges on the belt, and neutralise them. As the belt is continuously moving, positive charge accumulates on the dome.
- ③ The dome is a thin metal surface, but it has an outer and inner surface. As positive charge repels positive charge, the positive charge (here a deficit of electrons) accumulates on the surface of the dome. This is accordance with the principle of **Faraday's ice-pail experiment**.

SLIDE 19

QUESTION 10

State Coulomb's law

SLIDE 20

Coulomb's law

The force between two charges q_1 and q_2 is proportional to each of the charges and inversely proportional to the square of the distance r between them.

$$F \propto \frac{q_1 q_2}{r^2}$$

$$F = k \frac{q_1 q_2}{r^2} \text{ where } k = 8.99 \times 10^9 \text{ Nm}^2 \text{ C}^{-2} \text{ in a vacuum.}$$

The constant of proportionality is usually written $k = \frac{1}{4\pi\epsilon_0}$

where $\epsilon_0 = 8.85 \times 10^{-12} \text{ C}^2 \text{ N}^{-1} \text{ m}$ is the permittivity of free space.

$$F = \frac{1}{4\pi\epsilon_0} \cdot \frac{q_1 q_2}{r^2}$$

SLIDE 21

QUESTION 11

Define electric field strength. Derive an expression connected the electric force with the electric field strength.

SLIDE 22

The **electric field strength** is the force per unit positive charged at a given point within an electric field.

$$E = \frac{F}{q}$$

Hence

$$E = \frac{1}{q} \cdot \frac{1}{4\pi\epsilon_0} \cdot \frac{qQ}{r^2} = \frac{1}{4\pi\epsilon_0} \cdot \frac{Q}{r^2}$$

We also have from the definition

$$F = Eq$$

SLIDE 23

QUESTION 12

What is the expression for the field just outside a uniformly charged conducting sphere?

SLIDE 24

For the **field just outside a uniformly charged conducting sphere**, let σ be surface charge, Q be the total charge and R be the radius of the sphere. Then

$$\sigma = \frac{\text{total charge}}{\text{surface area}} = \frac{Q}{4\pi R^2}$$

Then the field strength just outside the sphere is

$$\begin{aligned} E &= \frac{Q}{4\pi\epsilon_0 r^2} \\ &= \frac{Q}{4\pi r^2} \times \frac{1}{\epsilon_0} \\ &= \frac{\sigma}{\epsilon_0} \end{aligned}$$

SLIDE 25

QUESTION 13

Define electric potential. Distinguish between electrical potential energy and electrical potential.

SLIDE 26

The **electric potential** at a point – this is the work done in moving a unit positive charge from infinity to the point, working against the electric force.

$$V = \frac{W}{q}$$

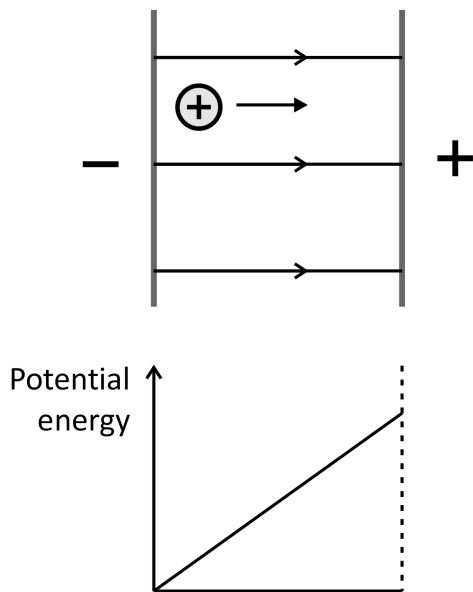

Whenever there is a separation of charge, there is **electrical potential energy**. To move a positively charged particle closer to another positive charge requires work. The potential energy increases linearly as the particle is pushed.

Potential, as opposed to potential energy, is energy per unit charge.

$$V = \frac{W}{q}$$

SLIDE 27

QUESTION 14

The dome of a Van de Graaff generator is a spherical conducting shell of radius 0.50 m. In air an electrical breakdown occurs with the intensity of the electric field is greater than $3 \times 10^6 \text{ Vm}^{-1}$.

- ① Estimate the maximum potential to which the dome can be raised.
- ② In what two ways can this maximum potential be increased?

SLIDE 29

Solution

$$E_{\max} = 3 \times 10^6 \text{ Vm}^{-1}$$

$$E = \frac{V}{q} \Rightarrow V = Eq$$

$$V = 3 \times 10^6 \times 0.5 = 1.5 \times 10^6 \text{ V}$$

Potential can be increased by increasing either the size of the dome (shell) or by encasing in a vacuum.

SLIDE 29

QUESTION 15

State the expression for the electric field strength of a uniform electric field across two parallel plates.

SLIDE 30

Solution

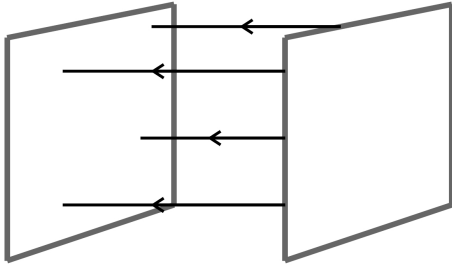

Between two parallel plates across which there is a potential difference V and a separation d there exists a **uniform field**.

For a uniform field the electric field strength is potential difference per unit distance.

$$E = -\frac{V}{d}$$

The units of field strength are **both** volts per meter, Vm^{-1} , and newtons per coulomb, NC^{-1} .

SLIDE 31

QUESTION 16

What is the electric field strength for a non-uniform field?

SLIDE 32

When the **electric field is not uniform** the electric field strength is the gradient of the potential, and the direction of the field is the same as the direction of decreasing potential.

This may be expressed in calculus by

$$E = -\frac{dV}{dx}$$

where x is the distance of the field from the point source.

QUESTION 33

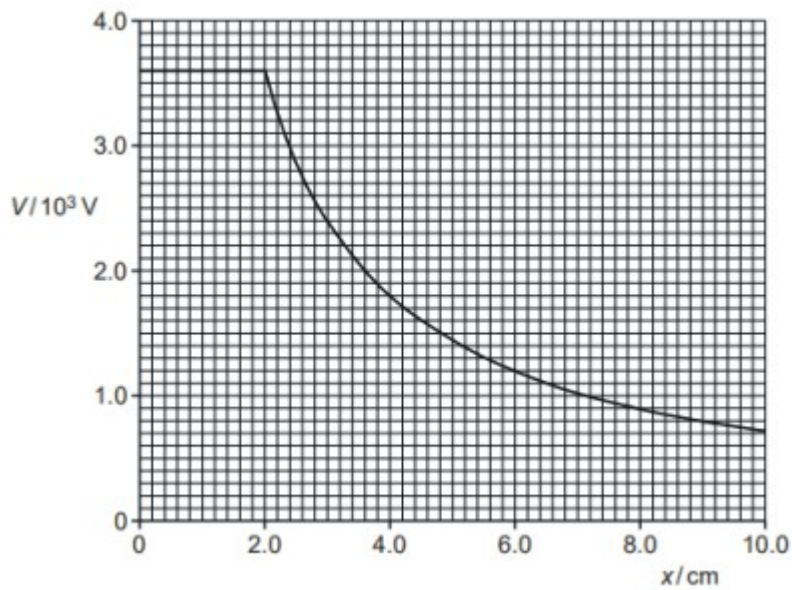

The figure shows the variation of electric potential V in the region of a charged metal sphere isolated in space for different distances x from the centre of the sphere.

How may the electric field strength at a given distance from the centre of the sphere be determined from the graph?

SLIDE 34

Solution

The electric field strength is the gradient of the potential graph.

For example, at

$$x = 0.4$$

$$E = \frac{\Delta V}{\Delta x} \approx \frac{3.5 \times 10^5}{0.08} = 4.5 \times 10^4 \text{ NC}^{-3}$$

SLIDE 35

QUESTION 18

Explain how an electron may be deflected by a uniform electric field. Find an expression for the force acting on a charged particle suspended between two plates with potential V .

SLIDE 36

Deflection in an electric field

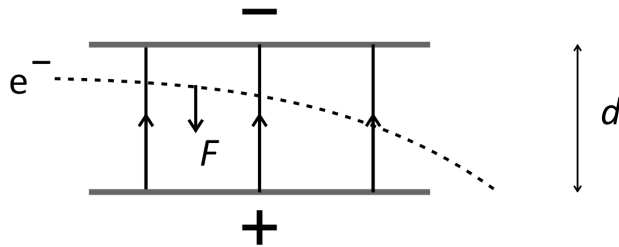

An electron passing between two charged plates travels in a parabola.

The force acting on a charged particle suspended between two

plates is $F = \frac{E}{d} = -\frac{Vq}{d}$.

SLIDE 37

QUESTION 19

Explain the Milikan oil-drop experiment.

Milikan oil-drop experiment

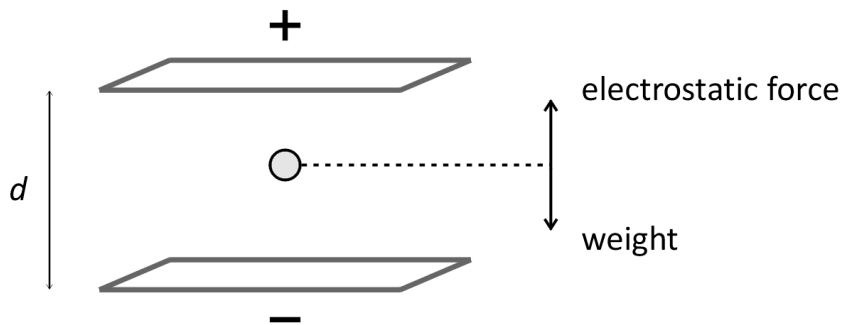

An oil drop that has been charged so that it has an excess of electrons is suspended between two conducting plates within an electric field. This produces an upward electrostatic force on the oil drop that is counterbalanced at equilibrium by gravity. From this experimental situation, the charge on the oil drop can be determined.

electrostatic force = weight

$$Eq = mg$$

$$-\frac{Vq}{d} = mg$$

$$q = -\frac{mgd}{V}$$

It was from this experiment that Milikan was able to demonstrate that the charge of an electron is discrete. An oil drop can carry a finite number of electrons, thus the charge on the oil drop is given by product of the number of excess electrons on the oil drop and the charge of the electron.

SLIDE 39

QUESTION 20

A potential difference of 400 V is applied across two parallel plane conductors separated by 20 mm.

- ① Find the potential gradient between the two plates.
- ② An oil drop placed between the two plates carries a charge of 8×10^{-19} C. What is the force on the oil drop?

SLIDE 40

Solution

① $d = 20 \text{ mm} = 0.02 \text{ m}, V = 400 \text{ V}$

$$E = \frac{V}{d} = \frac{400}{0.02} = 2 \times 10^4 \text{ Vm}^{-1}$$

② $E = \frac{F}{q} \Rightarrow F = Eq = 2 \times 10^4 \times 8 \times 10^{-19} = 1.6 \times 10^{-14} \text{ N}$

SLIDE 41

QUESTION 21

An oil drop is suspended stationary between two parallel horizontal metal plates that are 25 mm apart with a potential difference of 1000 V. If the mass of the drop is 5×10^{-15} kg, find the charge of the drop. Take $g = 10 \text{ Nkg}^{-1}$.

SLIDE 42

Solution

$$d = 25 \text{ mm} = 0.025 \text{ m}, V = 1000 \text{ V}, m = 5 \times 10^{-15} \text{ kg}$$

Electrostatic force = weight

$$F = W$$

$$Eq = mg$$

$$E = \frac{V}{d} \Rightarrow \frac{Vq}{d} = mg$$

$$\frac{1000 \times q}{0.025} = 5 \times 10^{-15} \times 10$$

$$q = \frac{5 \times 10^{-15} \times 10 \times 0.025}{1000} = 1.25 \times 10^{-18} \text{ C}$$

SLID3 43

QUESTION 22

What is earth in electrostatic theory?

SLIDE 44

The **zero of the electric potential** is determined by an arbitrary decision. We usually define the **earth** to be the zero potential.

SLIDE 45

QUESTION 23

Give an expression for the field strength in a radial field.

SLIDE 46

Field strength in a radial field

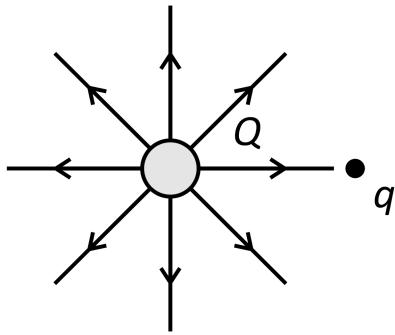

$$F = \frac{Qq}{4\pi\epsilon_0 d^2}$$

$$F = Eq$$

$$E = \frac{Q}{4\pi\epsilon_0 d^2}$$

SLIDE 47

QUESTION 24

29 The diagram shows two metal plates connected to a constant high voltage.

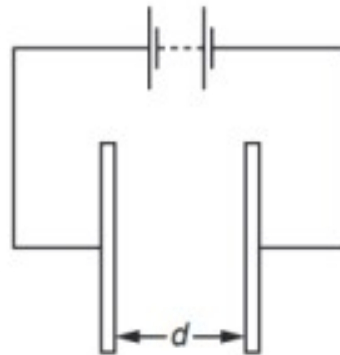

Which graph shows the variation of the electric field strength E midway between the distance d between the two plates is increased?

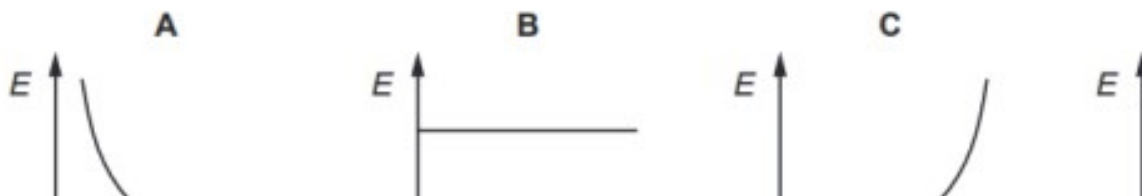

SLIDE 48

Solution

A

SLIDE 49

QUESTION 25

What are equipotentials?

Make diagrams of equipotentials in a (a) a radial and (b) a uniform field.

Equipotentials

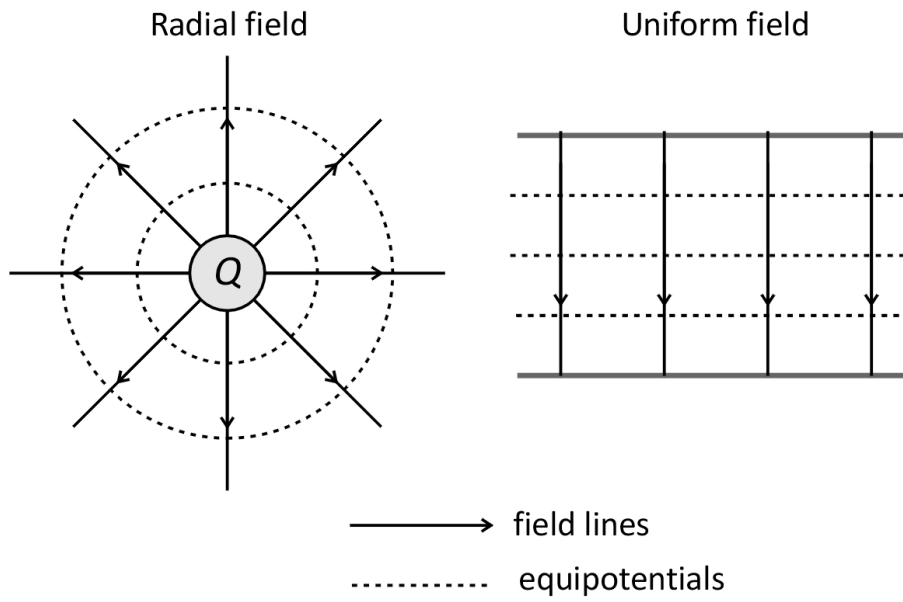

SLIDE 51

QUESTION 26

Derive an expression for the potential at a distance d from a charge Q .

SLIDE 52

Electric potential

Given that electric potential at a point is the work done in moving a unit positive charge from infinity to the point, working against the electric force, then the potential in a radial field is

$$V = -\frac{E}{q}$$
$$V = -\frac{\left(\frac{Q}{4\pi\epsilon_0 d^2}\right)}{d}$$
$$V = -\frac{Q}{4\pi\epsilon_0 d}$$

This is the potential at a distance d from a charge Q .

We must define the zero potential. Calculations are easiest if we define the potential at infinity to be zero.

This definition makes the potential of a positively charged particle (like charges) positive for any finite separation d , and negative for a negatively charged particle (unlike charges).

The electric potential at a point is equal to the work done per unit charge in moving a positive charge from infinity to that point.

SLIDE 53

QUESTION 27

Make a diagram showing how field strength is related to potential gradient for (a) like and (b) unlike charges.

Field strength and potential gradient

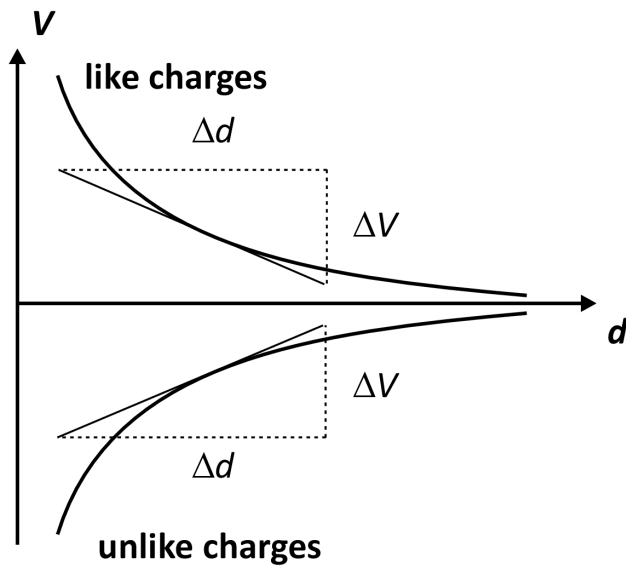

The field strength is the slope of the potential gradient.

field strength = $-\text{potential gradient}$

SLIDE 55

QUESTION 28

What are the similarities between the electrostatic and the gravitational force

Comparison of the electrostatic to the gravitational force

Gravity	Electrostatic
$F = \frac{GMm}{r^2}$	$F = \frac{1}{4\pi\epsilon_0} \cdot \frac{q_1q_2}{r^2}$

These equations tell us that for **both** the gravitational and electrostatic forces:

- 1 The force is proportional to the product of the mass or charges respectively.
- 2 If one of the masses (charges) is held constant, then the force is proportional to the mass (charge) of the other.
- 3 The force is inversely proportional to the square of the distance. $F \propto \frac{1}{r^2}$. This is called the **inverse square law**.
- 4 The surface area of a sphere is given by $4\pi r^2$.

The inverse square law for both the gravitational and electric force indicates that the total force exerted by a mass (charge) over the surface of a sphere of radius r is constant.

QUESTION 57

What distinguishes the gravitational from the electrostatic force?

SLIDE 58

- 1 The electrostatic force exists between charged particles and is attractive and repulsive, unlike gravity, which is always attractive. Like charges repel, unlike charges attract.
- 2 Since G is a universal constant, the gravitational force does not depend upon the medium or substance that separates the two masses. However, for the electrostatic force, the force law is $F = \frac{1}{4\pi\epsilon_0} \cdot \frac{q_1q_2}{r^2}$. In this ϵ_0 is the **permittivity of space**, a constant for a vacuum. The permittivity of other substances (for example, air, wood, iron...) differs.

Hence, while there is **no insulation** against gravity, materials may be classified as insulators or conductors of the electrostatic force.

- 3 As gravity causes objects to accelerate, an object moving from infinity increases in velocity, and hence kinetic energy. Potential energy increases as the separation of the two masses increases. Hence, by defining the potential energy at infinity to be zero, this means that that potential energies of masses are always negative.

QUESTION 59

Show in a diagram the relation between field strength and potential.

Relation between electric field strength and potential

